

BHP Series – Ingress Protection High Intensity Back Light

The BHP series is an ingress protection illumination where the LEDs are arranged in a dense array and shine into a diffuser and provides area illumination.

Application: lead frame inspection, shape recognition, size measurement

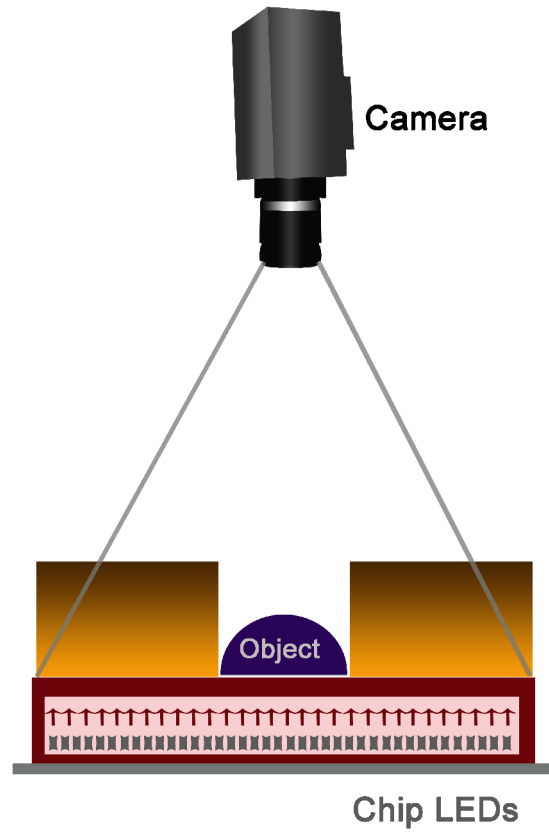
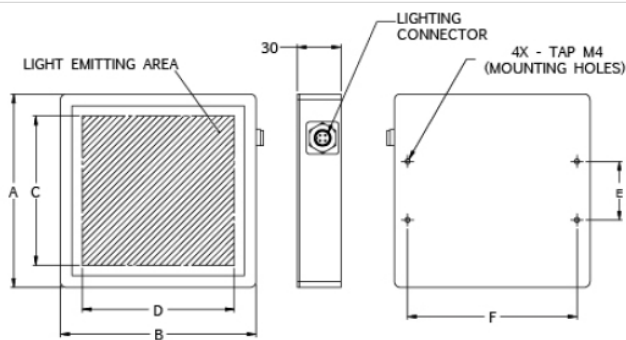
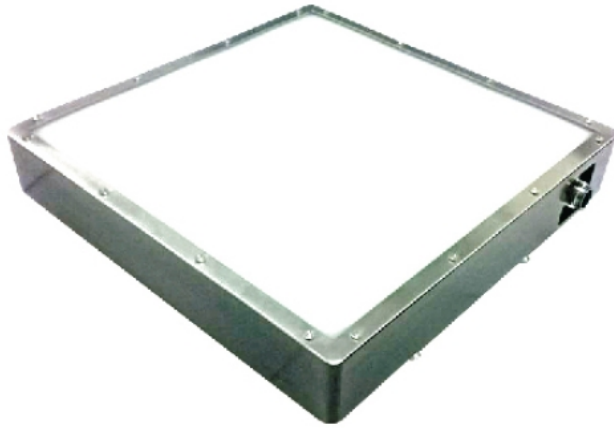

Model	Dimensions (mm)						Color	Voltage/ Watt	Current
	A	B	C	D	E	F			
BHP1010-X-X	132	134	102	104	40	116	●	24V / 9.12W	380mA
							● ● ○	24V / 6.84W	285mA
BHP1515-X-X	180	180	150	150	75	163	●	24V / 18.48W	770mA
							● ● ○	24V / 20.16W	840mA
BHP1520-X-X	180	230	150	200	75	213	●	24V / 23.04W	960mA
							● ● ○	24V / 20.16W	840mA